



# CLOSED BODY STANDARD PINCH VALVE SPV

The SPV pinch valve is a standard duty enclosed body center line closure valve that employs elastomer sleeves for flow shut-off and control in applications with abrasive and corrosive slurries. The sleeve is the only part in contact with the media, no other mechanical parts are required, and it is a maintenance free part.

## Main Features:

- Bi-directional operation, both for on/off and throttling service.
  - Body to be Fabricated Steel
  - AIS available upon request
  - Clog resistant, 100% full bore design with no flow restrictions and turbulence, and self-cleaning.
  - Enclosed body, protecting the sleeve from outside conditions.
  - Sleeve is the only part exposed to the line process, no other mechanical parts required.
  - Double pinch closing mechanisms.
  - Reduced process downtime and maintenance cost with easy and quick replacement.
  - Manual and pneumatic (single and double acting) actuators. Electric and hydraulic actuators available upon request.
- 
- Same face-to-face distance as that for gate, plug or ball valves up to 6"/DN150.
  - Operation under vacuum conditions feasible.



# TRINOVA SLEEVES

- Size: 1"-12".
- Type: Full Port, Cone, Cone Funnel, High Pressure.
- Materials of Construction: PGR, EPDM, SBRT, NEOPRENE, Buna-N, Viton and Teflón Liner.
  - \*Other sizes and materials available.
- Sleeve Wear Sensor with communication module available.

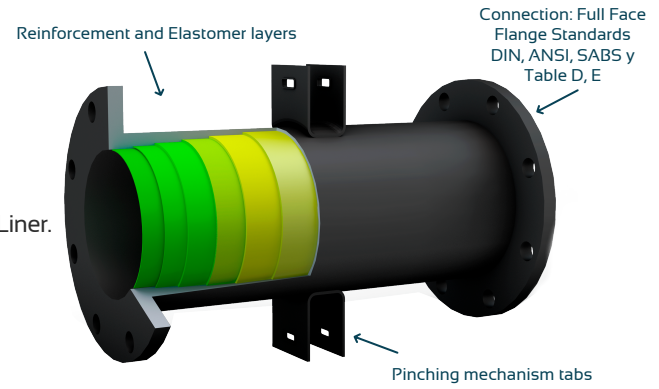

Name	Temperature	Compatibility
Pure Gum Rubber PGR	-50 F to 180 F	Good abrasion resistance, tensile strength and resiliency. Good Compatibility with weak chemicals, organic acids and alcohols.
EPDM	-50 F to 300 F	Good abrasion resistance at higher temperatures. Good for diluted acids, steam, water and ketones. Not recommended for hydrocarbons.
Neoprene	-50 F to 230 F	Resistant to moderate chemicals, ozone, fats and some hydrocarbons.
SBR	40 F to 180 F	Good abrasion resistance, crack endurance and positive ageing characteristics.
Buna - N	-30 F to 230 F	Resistant to moderate chemicals, kerosene, grease, oils, fats and some hydrocarbons.

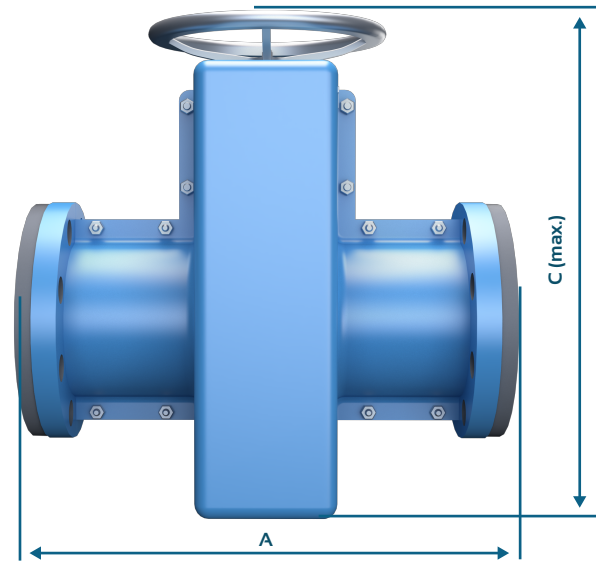
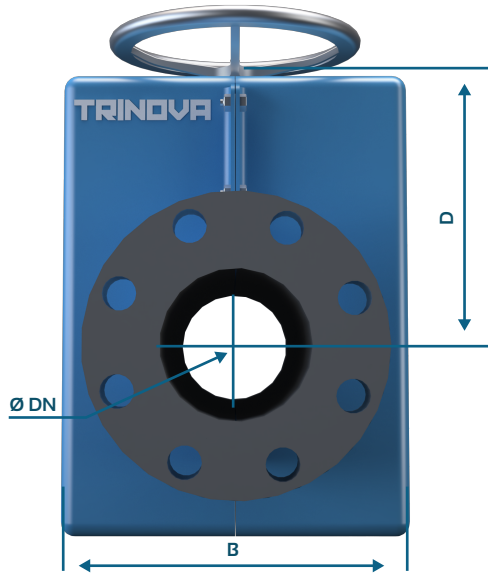

DN	A	B	C	D	Air pressure (psi)	Weight (lbs)
1"	5.5	5.1	17.7	14.7	60 to 110 psi	13
1 ½"	6.5	7.4	20	16.3	60 to 110 psi	22
2"	7	8.8	22.8	18.9	60 to 110 psi	35
2 ½"	7.4	10.4	25.3	20	60 to 110 psi	49
3"	7.9	11.8	29.1	22.6	60 to 110 psi	64
4"	9	13.7	33.4	27.7	60 to 110 psi	95
6"	10.4	16.9	36.2	29.3	60 to 110 psi	276
8"	15.9	21.6	46	37.2	60 to 110 psi	353
10"	20	25	49.2	36.6	60 to 110 psi	419
12"	23.6	34.6	53.1	41.3	60 to 110 psi	507

Trinova follows the industry standard ISA 75.10.02 for installed face to face dimensions.



[www.trinovausa.com](http://www.trinovausa.com)



[sales@trinovausa.com](mailto:sales@trinovausa.com)