

DUAL PIVOT FLANGED GATE VALVE

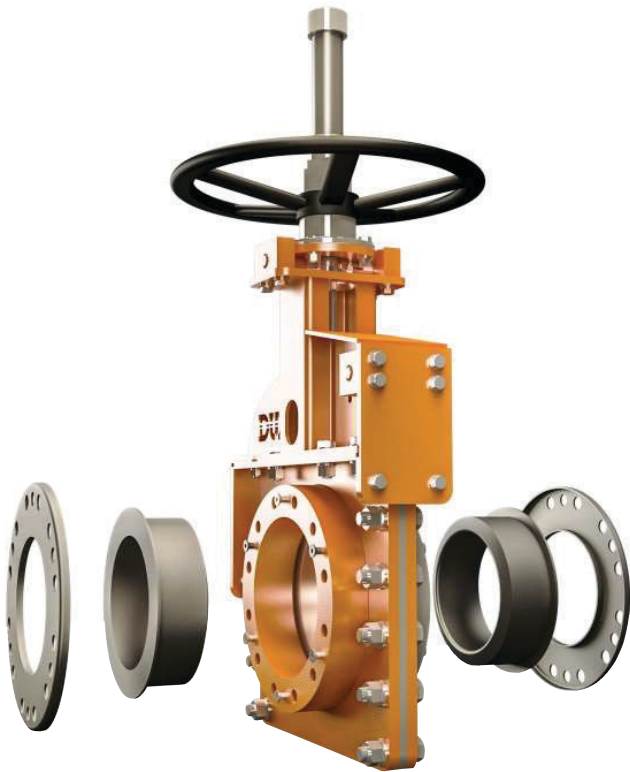

DUAL's Pivot Flanged Gate Valve is built with a steel body and features a heavy-duty Stainless Steel gate. Removable sleeves on either side of the gate provide a bi-directional bubble tight seal, with no metal parts in contact with the slurry. The Dual Pivot gate valve provides faster operation and occupies less vertical space within the process pipeline.

PRODUCT SPECIFICATION

SIZE RANGE: 80mm to 1500mm.

BODY TYPE: Fabricated Carbon Steel.

PRESSURE RATINGS: DN80 to DN600 rated to 360Psi / (25 Bar) using 316SS Blade, DN650 to DN1500 - 150Psi (10 Bar).

ELASTOMER SLEEVES: Gum Rubber (standard), Nitrile, EPDM, Neoprene or Butyl.

RETAINER FLANGES: Rubber covered Carbon Steel flanges (80mm through to 1500mm).

GATE MATERIAL: 316 Stainless Steel standard - 316L, 317L, 17-4PH, Alloy 20, SAF 2205 S/S with optional wear coatings.

DRILLING PATTERNS: DN80 to DN250 drilled and tapped ASME B16.5, BS, DIN, SABS. DN300 to DN1500 flanges are slotted.

MATERIAL CERTIFICATION: Certified chemical and physical test reports can be supplied.

FEATURES

- 360Psi / 25 Bar (Higher pressures on request).
- Double seat design for heavy duty slurry service.
- Ease of replacement of sleeves.
- When open, the gate is fully pivoted out of the slurry flow.
- Gate guard.
- Bubble tight shutoff, zero downstream leakage.
- No clogged bonnet to impede flow.
- External epoxy coated.
- Easily adapted to suit most actuators.
- Low maintenance requirements.
- Suitable for wet or dry service.
- Bi-directional flow.
- Packingless design.
- Rotary style movement of the gate.
- Flush ports.
- Light weight for easier handling.
- No seat cavity where solids can collect and prevent full gate closure.

RSA RegD. Design No. F2017/01372
 RegD. Design No. A2017/01371
 Patent No. 2017/05831

STANDARD FEATURES - VALVE BODY

- Splash guard with flush ports.
- Protective bellows.
- Open/closed lock out.
- Lubrication ports on both sides of the valve body.
- Limit switch brackets.
- Adaptable tower design can be field modified to take air cylinder, gearbox, hydraulic or electric actuators.

APPLICATIONS

- Mining and mineral processing.
- Power generation.
- Sand and gravel.
- Chemical and soda ash.
- Pulp and paper.

DIMENSIONS AND WEIGHTS

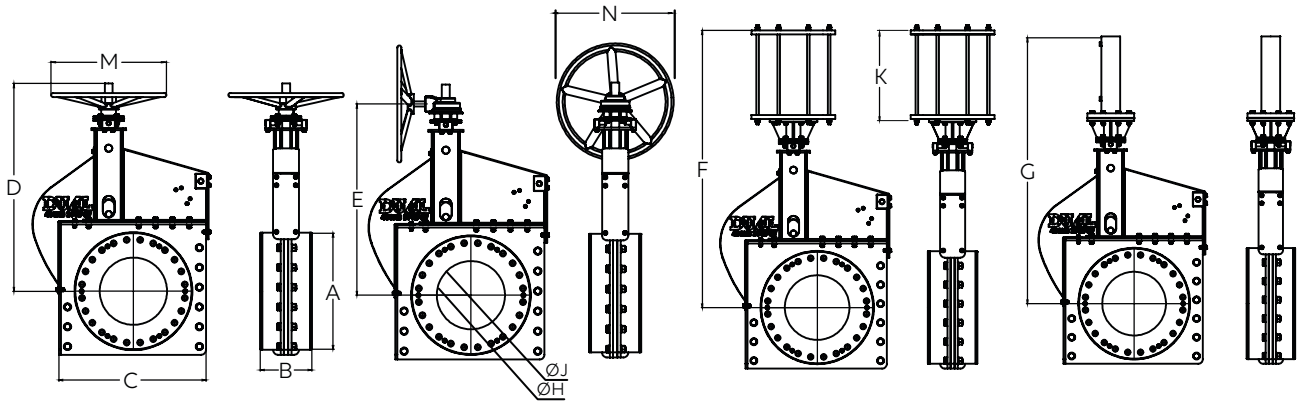

HOW THE RUBBER SLEEVES WORK

Matching rubber ring sleeves with stiffener rings are placed in the valve housing to seal against the gate when the valve is closed and seal against each other when the valve is open. This tight seal contains the high internal line pressure. Double seated design provides bi-directional flow and shut off.

ACTUATORS

All types of actuators can be fitted, electric, gearbox, hydraulic, pneumatic or handwheel.

ACCESSORIES

- Limit switches.
- PTFE coating of gate.
- Various blade materials optional.
- Gate safety guards.

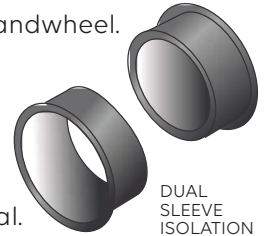

VALVE SIZE (mm)	DIMENSIONS (mm)												WEIGHT (kg)			
	AØ	B	C	D	E	F	G	HØ	JØ	K	M	ØN	HW	BG	AC	HYC
80	191	175	320	481	544	545	624	62	72	403	300	300	30	58	39	58
100	229	175	340	553	593	609	702	85	99	429	300	300	40	65	60	65
150	280	178	405	712	809	679	864	137	148	455	500	500	50	80	85	85
200	343	185	460	836	379	890	974	175	197	483	500	500	65	97	916	96
250	407	226	515	985	1083	1029	1124	231	249	595	500	500	90	125	141	100
300	483	258	565	1206	1206	1156	1350	274	293	648	600	600	170	194	304	165
350	536	258	625	1355	1355	1358	1469	318	337	671	600	600	200	204	327	188
400	591	280	685	1453	1453	1529	1628	356	375	703	700	700	240	260	512	250
450	639	312	735	1693	1693	1718	1747	378	426	771	700	700	260	397	604	431
500	693	359	790	1828	1828	1867	1891	421	470	795	700	700	330	479	763	545
600	813	372	900	2190	2190	2236	2277	539	585	883	700	700	480	490	993	636
650	870	373	950	-	-	-	2495	597	636	-	-	-	-	-	-	773
750	1010	397	1000	-	-	-	2750	680	737	-	-	-	-	-	-	976
900	1180	469	1235	-	-	-	3320	810	890	-	-	-	-	-	-	1588
1000	1360	534	1350	-	-	-	4400	972	1041	-	-	-	-	-	-	2359
1200	1520	534	1575	-	-	-	4500	1120	1315	-	-	-	-	-	-	3162
1400	1720	534	1800	-	-	-	4655	1244	1525	-	-	-	-	-	-	3755
1500	1855	534	2000	-	-	-	4780	1455	1525	-	-	-	-	-	-	4500

Contact Dual for larger sizes. Dimensions and weights are for guidance only - detailed dimension drawings available on request. All dimensions are in millimeters, unless stated.

CORPORATE HEADQUARTERS:
166 ROTTERDAM ROAD
(CNR ROTTERDAM ROAD & ANTWERP STREET)
APEX, BENONI, GAUTENG, SOUTH AFRICA

PO BOX 12520, BENORYN 1504
TEL: +27 11 422 4326/7
FAX: +27 11 421 7842
EMAIL: SALES@DUALVALVES.COM