



# AIR PINCH VALVE

## APV

Trinova's APV pinch valve is a simple yet reliable on/off pinch valve for multiple process applications. This valve consists of two identical half cast or fabricated bodies and one rubber sleeve as well as gaskets to ensure no leak paths of air from the housing. The valve is closed by directly adding air fluid into the body. Differential pressure should be 35-40 psi above the line pressure in order to close the sleeve. The rubber sleeve will provide bi directional drop tight seal.



### Features:

- Tube and shell design, bidirectional operation for on/off low pressure applications in which housing acts as a built-in actuator.
- Flanges tapped for ANSI 125/150 lb or DIN drilling.
- Bodies: Cast Iron and Fabricated Steel Aluminum available.
- Sleeve Materials: PGR, EPDM, Neoprene, Buna-N and others available upon request.
- Rugged, lightweight and economical for various applications.
- 100% full port eliminates clogging and turbulence as well as generating low pressure drops.
- Automation is inexpensive and can operate as a non-critical control valve.
- Rubber sleeve is the only part exposed to the process fluid.
- Full flat-faced integral elastomer flanges.
- Can be installed in any position.

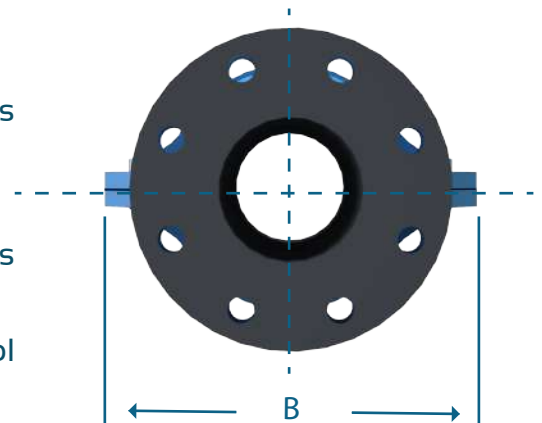

APV				
Size	Weights (lbs)	A	B	C
1"	7	5"	6"	4 1/4"
1.5"	12	7"	8"	5"
2"	16	9"	10"	6"
2.5"	25	10"	11"	7"
3"	33	12"	13"	7 1/2"
4"	47	12 1/2"	13 1/2"	9"
5"	65	16 1/2"	17 1/2"	10 1/4"
6"	82	20"	21"	11 1/2"
8"	124	22"	24"	13 1/2"
10"	*	24"	26"	16"
12"		26"	28"	19"
14"		30"	34"	23"
16"		34"	38"	25 1/2"
18"		39"	43"	27"
20"		43"	47"	29 1/2"
24"		51"	55"	34"

# TRINOVA SLEEVES

- Size: 1"-24".
- Type: Full Port, Cone, Cone Funnel, High Pressure.
- Materials of Construction: PGR, EPDM, SBRT, NEOPRENE, Buna-N, Viton and Teflón Liner.
- \*Other sizes and materials available.
- Sleeve Wear Sensor with communication module available.

Name	Temperature	Compatibility
Pure Gum Rubber PGR	-50 F to 180 F	Good abrasion resistance, tensile strength and resiliency. Good compatibility with weak chemicals, organic acids and alcohols.
EPDM	-50 F to 300 F	Good abrasion resistance at higher temperatures. Good for diluted acids, steam, water and ketones. Not recommended for hydrocarbons.
Neoprene	-50 F to 230 F	Resistant to moderate chemicals, ozone, fats and some hydrocarbons.
SBR	40 F to 180 F	Good abrasion resistance, crack endurance and positive ageing characteristics.
Buna - N	-30 F to 230 F	Resistant to moderate chemicals, heronsene, grease, oils, fats and some hydrocarbons.

